

Wildlife-Friendly Wire Fence

Conservation Practice 382 - Job Sheet

January 2010

Client: _____

FENCES AND WILDLIFE

Although fences are often necessary to improve land management, they can pose a number of risks to wildlife. Animals can collide or become entangled with fences, which frequently results in injury or death. Fences can also be barriers to animal movement that can limit access to critical habitat resources or separate juveniles from adults. The level of risk a fence poses depends upon many factors, such as fence type, total height, wire spacing, visibility, location on the landscape, wildlife species present, and season of wildlife use.

The most desirable situation for wildlife is a landscape without fences. However when fences are needed, it is best to incorporate “wildlife-friendly” elements into fence design. Wildlife-friendly fences allow for safe passage of wildlife over or under fences and are highly visible, especially to ungulates and birds.

PLANNING FRIENDLY FENCE

The primary purpose of the fence will direct its design and placement. However, it may be feasible to achieve the primary purpose while accommodating wildlife. Identify what you are trying to control with the fence and determine the minimum requirements needed to achieve the desired level of control. Determine which wildlife species are in the area and when and where they may encounter the fence. In most areas, ungulates and large birds (e.g., grouse and raptors) will have the most difficulty with fences. Sometimes wildlife-fence interactions are more prevalent during specific seasons or locations when wildlife are moving through the area. Use this information to help decide what wildlife-friendly elements can be incorporated into the fence design.

A number of fence design modifications can be made to improve conditions for wildlife. The vast majority of adult ungulate mortalities occur when animals get caught in the top two wires. Set the total fence height as low as possible. Keep in mind that slope of the land increases the effective height of the fence. In most cases, a 40-inch tall fence on level ground with a minimum 12-inch spacing between the top two wires will be sufficient to prevent adult ungulate

mortalities. Additional accommodations will be needed to allow for passage under the fence for animals like antelope and juvenile ungulates that prefer not to, or are incapable of, jumping over the fence. Whenever feasible, use smooth wire for the top and bottom wires to reduce injuries.



Increasing fence visibility will also help reduce wildlife injury and fence damage. Frightened ungulates, diving raptors, and low-flying birds like grouse and waterfowl frequently strike wire fences simply because they do not see them. Avoid placing fences in travel corridors or other areas heavily used by wildlife. If that isn't possible, several techniques are available to increase wire visibility, such as, slipping PVC pipe onto the top wire, using vinyl-coated white wire, or attaching durable flagging or other markers. Where wildlife concentrate, it may be more desirable to install segments of let-down or adjustable-wire fence to facilitate wildlife passage.

FENCE MAINTENANCE

A wildlife-friendly fence should result in less maintenance due to reduced wildlife damage. However, regular inspection of fences should continue to be part of an ongoing maintenance program. Wires should be kept tight. Loose wires can snag wildlife and increase the likelihood of entanglement. Inspection of fences after storm events is necessary to insure the continued proper function of the fence. Maintenance and repairs will be performed in a timely manner as needed.

382AA OR - Specification

Natural Resources Conservation Service, Oregon

January 2010

WILDLIFE-FRIENDLY WIRE FENCE SPECIFICATION SHEET

Client		Date	
Farm/Tract		Field(s)	
Location		Length(s) (ft)	
Planner		County/SWCD	

Design Approval:

Practice code No.	Practice	Lead Discipline	Controlling factor	Units	Job class				
					I	II	III	IV	V
382	Fence	BCSD Graz Land Spec	Length	feet	All	All	All	All	All
			Animal Units	AUE	25	100	250	350	All
This practice is classified as Job Class (check one):									

Design Approved by: /s/ _____ Date: _____

Job title: _____

Client's Acknowledgement Statement:

The Client acknowledges that:

- a. They have received a copy of the specification and understand the contents and requirements.
- b. It shall be the responsibility of the client to obtain all necessary permits and/or rights, and to comply with all ordinances and laws pertaining to the application of this practice.

Accepted by: /s/ _____ Date: _____

Certification:

I have completed a review of the information provided by the client and certify this practice has been applied.

Certification by: /s/ _____ Date: _____

Job title: _____

Refer to the Following Conservation Practice Specifications [X]			
Access Control 472		Prescribed Grazing 528	
Range Planting 550		Critical Area Planting 342	
Pipeline 516		Watering Facility 614	
Spring Development 574		Wetland Wildlife Habitat Management 644	
Upland Wildlife Habitat Management 645		Other:	

USDA Nondiscrimination Statement

The U.S. Department of Agriculture (USDA) prohibits discrimination in all its programs and activities on the basis of race, color, national origin, sex, religion, age, disability, political beliefs, sexual orientation, and marital or family status. (Not all prohibited bases apply to all programs.) Persons with disabilities who require alternative means for communication of program information (Braille, large print, audiotape, etc.) should contact USDA's TARGET Center at 202-720-2600 (voice and TDD).

To file a complaint of discrimination write USDA, Director, Office of Civil Rights, Room 326-W, Whitten Building, 14th and Independence Avenue, SW, Washington, DC 20250-9410 or call 202-720-5964 (voice or TDD). USDA is an equal opportunity provider and employer.

WILDLIFE-FRIENDLY WIRE FENCE SPECIFICATION SHEET

1. **MANAGEMENT OBJECTIVES:** _____
2. **FENCE TYPE (check all that apply):** **Barbed Wire** **Smooth Wire** **3-Wire** **4-Wire**
3. **ADDITIONAL SPECIFICATIONS:** _____
- See attached designs, drawings, and/or maps.

4. CONSTRUCTION SPECIFICATIONS

GENERAL

Installation shall be in accordance with an approved plan. Details of construction shown on the drawings but not include herein are considered as part of these specifications. Construction activities shall be in accordance with applicable OSHA regulations.

Prior to construction the fence lines shall be cleared of any possible obstruction that would hinder the fence placement and operation.

The soil surface along the fence line shall be relatively smooth such that placement of the bottom fencing member does not exceed the maximum fence member to soil surface spacing specified.

The fence materials shall have an expected life of at least 10 years with routine maintenance. All wood materials except Orange Osage, Western Red Cedar, Juniper and Black Locust that have contact with the soil shall be treated with an EPA-registered wood preservative. Wood posts shall be treated from the butt end of the post to distance of at least 30 inches for line posts and 36 inches for all corner, gate and brace posts. Refer to Table 1 for the life expectancy of treated versus untreated wood posts.

MATERIALS

Wood Posts: Line posts shall have a minimum top diameter of 3 inches and shall be a minimum of 6 feet in length. Corner, gate and brace posts shall have a minimum top diameter of 5 inches and shall be a minimum of 7 feet in length. Braces shall have a minimum diameter of 4 inches and shall be a minimum of 8 feet in length.

Steel Posts: Steel line posts shall be the "T", "U" or "Y" type with a welded or riveted anchor plate near the bottom (minimum 18 inches square area) and have suitable corrugations, knobs, studs or grooves for fastening the wire. Line posts shall weigh at least 1.33 pounds per linear foot of length and shall be a minimum of 5.5 feet long.

Steel Pipe Posts: Steel pipe corner, gate or brace posts shall be a minimum diameter of 2 inches, Schedule 40 (2.375-inch O.D.) and at least 7 feet long. Bracing shall be a minimum of 1-1/2 inch nominal diameter, Schedule 40 pipe. Brace fittings and clamps shall be galvanized.

Angle Section Posts: Angle section posts shall have nominal sectional dimensions of 2.5 by 2.5 by 0.25 inches thick and at least 7 feet in length. Braces shall be of the

same size dimensions as corner and gate posts and shall be a minimum of 6 feet in length.

Table 1: Life Expectancy of Untreated and Treated Fence Posts (Years)

Kind of Wood	Untreated	Pressure Treated	Hot and Cold Bath	Cold Soak
Western Red Cedar	12-15	20-25	20-25	-
Lodgepole & Ponderosa Pine	2-4	20-25	15-20	10-20
Aspen or Cottonwood	1-3	15-20	10-15	5-10
Douglas Fir & Western Hemlock	3-6	20-35	15-25	10-20

Vinyl Coated Wire: Vinyl coated wire (white in color), high tensile and a minimum of 12.5-gauge.

Smooth Wire: Smooth wire shall be a single steel wire of 9-gauge or heavier, two wrapped strands of 12.5-gauge or heavier wire or 12.5-gauge or heavier hi-tensile wire. Wire shall have a minimum tensile strength of 45,000 psi.

Barbed Wire: Barbed wire shall be composed of two strands of 12.5-gauge zinc coated wire wrapped around each other, with 2-point 14 gauge barbs spaced no more than 5 inches apart conforming to ASTM A 121.

Wire Fasteners: Staples shall be 9-gauge or heavier and have a minimum length of 1.5 inches, except 1.0 inch staples are allowed on very hard woods. Fasteners for use with steel posts shall be 12-gauge or heavier zinc coated wire.

Stays: Wire stays shall be 9.5-gauge or heavier, zinc coated, twisted wire. The length shall be at least two inches longer than the distance between the top and the bottom strands of the fence. Wood stays shall be sound, straight pieces at least 2 inches in diameter.

WILDLIFE-FRIENDLY WIRE FENCE SPECIFICATION SHEET**INSTALLATION**

The fence shall be reasonably straight and shall not deviate more than 12 inches between any corner and gate or line brace assembly.

Post Depth: Line steel posts shall be set a minimum depth of 1.5 feet and wood line posts shall be set to a minimum depth of 2 feet, unless otherwise specified. Gate, corner and brace posts shall be set to a minimum depth of 3 feet, unless otherwise specified. Steel pipe and angle section posts shall be embedded in a 12-inch circular or square concrete pier, except when set in firm rock.

Post Spacing: The maximum post spacing interval shall be 20 feet on fences without fence stays, 25 feet with one stay between posts, and 30 feet with two stays between posts.

Line Bracing: Line brace assemblies shall be located at all corners, gates and abrupt changes in vertical topography (generally considered as 15 degrees). On straight reaches of fencing line braces shall be installed at a spacing of no more than 1300 feet.

Wire Spacing: Distance from ground to top wire shall not exceed 42 inches (total fence height). A maximum height of 40 inches or less is preferred. The top 2 wires must be spaced at least 12 inches apart. The distance from ground to bottom wire shall be at least 16 inches.

EXCEPTION: If it is necessary to control sheep or calves with the fence, the ground to bottom wire spacing may be reduced to 10 inches as long as the total fence height does not exceed 32 inches.

Wire Type: Smooth or barbed wire may be used. In all cases, the bottom wire shall be smooth.

Wire Fasteners: Staples shall be driven diagonally into the wood grain of the post. Space shall be left between the post and the staple to allow movement of the wire. Fasteners on steel posts shall be snug enough to prevent vertical movement of the wire on the post.

Stays: Stays shall be uniformly spaced between the posts as required for the specified post spacing.

Drainageways: In crossing drainageways or depressions a weight or deadman anchor shall be fastened to the fence to maintain the required spacing interval or additional wires shall be added to maintain the required minimum wire height from the ground.

Wire Visibility: All new fences should be marked with at least temporary flagging. In travel corridors or areas of heavy use, implement one or more of the following to increase wire visibility: 1) use durable markers such as small pieces of white vinyl siding to mark wires, 2) use white vinyl-coated wire or other high visibility wire for top wire, or 3) slip sections of PVC pipe onto top wire.

If compatible with livestock management, it may be also be appropriate to install a section of let-down or adjustable-wire fence to facilitate heavy wildlife movement during seasonal use periods. Refer to Paige (2008) for designs.

OPERATION AND MAINTENANCE

Regular inspection of fences should be part of an ongoing maintenance program. Inspection of fences after storms and other disturbance events is necessary to insure the continued proper function of the fence. Maintenance and repairs will be performed in a timely manner as needed, including tree/limb removal and water gap replacement.

Monitor fences to ensure safe passage for wildlife. If problem areas are detected, measures should be taken to reduce or eliminate threats to wildlife.

Remove and properly discard all broken fencing material and hardware. All necessary precautions should be taken to ensure the safety of construction and maintenance crews.

REFERENCES

George Miksch Sutton Avian Research Center. 2006. Fence marking for lesser prairie-chickens: a cooperative

conservation solution. Sutton Avian Research Center, Bartlesville, OK. 2 pp. Online: http://www.suttoncenter.org/fence_marking.html

Harrington, J.L., and M.R. Conover. 2006. Characteristics of ungulate behavior and mortality associated with wire fences. *Wildlife Society Bull.* 34(5)1295-1305.

Paige, C. 2008. A Landowner's Guide to Wildlife Friendly Fences. Landowner/Wildlife Resource Program, Montana Fish, Wildlife, and Parks, Helena, MT. 44pp.

Wyoming Game and Fish Dept. 2004. Fencing guidelines for wildlife. Revised version Habitat Extension Bulletin No.

53. Wyoming Game and Fish Dept. 12 pp.

WILDLIFE-FRIENDLY WIRE FENCE SPECIFICATION SHEET

Standard Wildlife-Friendly Wire Fence Drawings

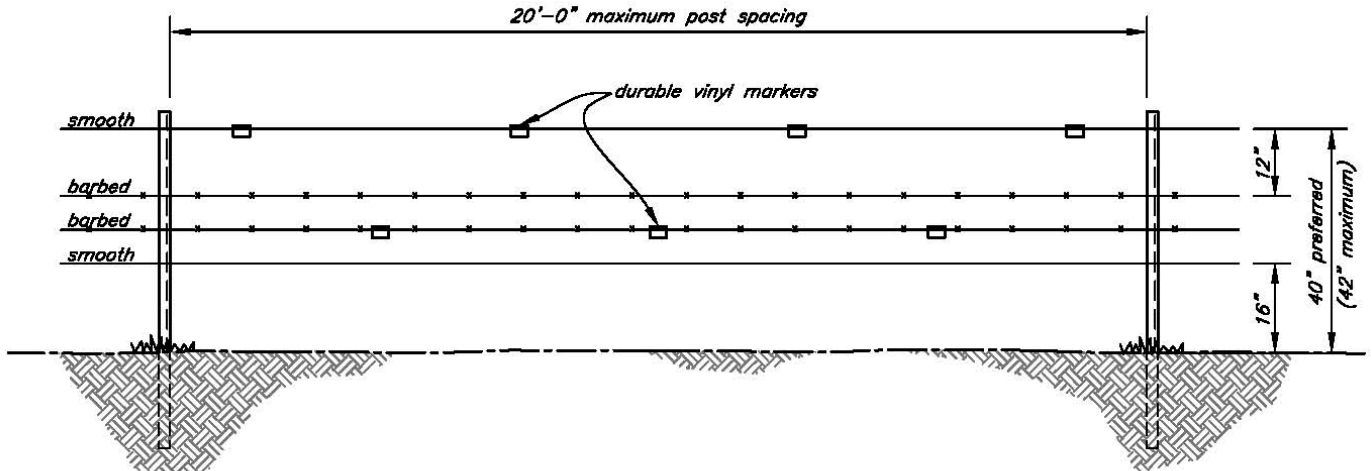

4-STRAND BARBED & SMOOTH WIRE FOR AREAS WITH LIVESTOCK AND WILDLIFE PRESSURE

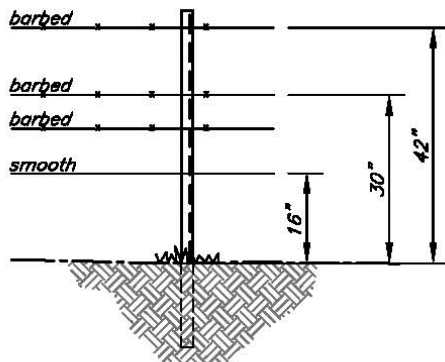

4-STRAND BARBED & SMOOTH WIRE FOR AREAS OF REGULAR LIVESTOCK PRESSURE

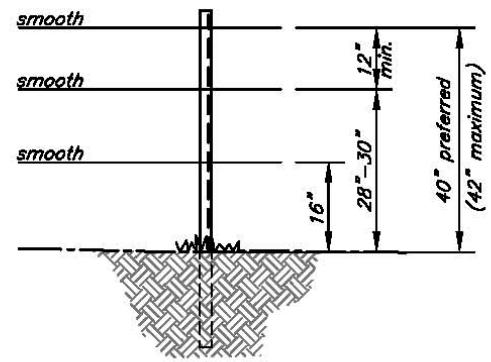

(for additional livestock control, used barbed wire instead of smooth wire on top 2 strands)

3-STRAND SMOOTH WIRE FOR AREAS OF LIGHT LIVESTOCK PRESSURE

WILDLIFE-FRIENDLY WIRE FENCE SPECIFICATION SHEET

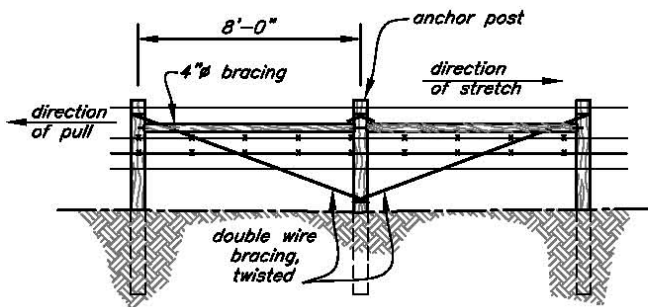

LINE BRACE

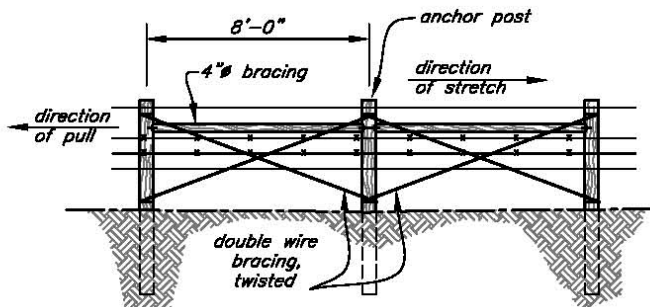

LINE BRACE

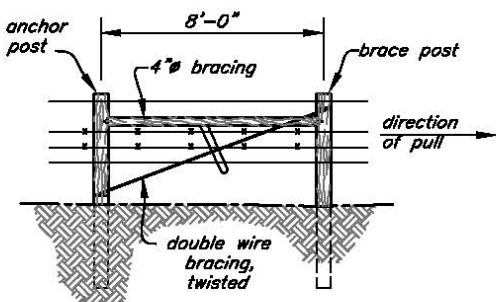

1-SPAN END

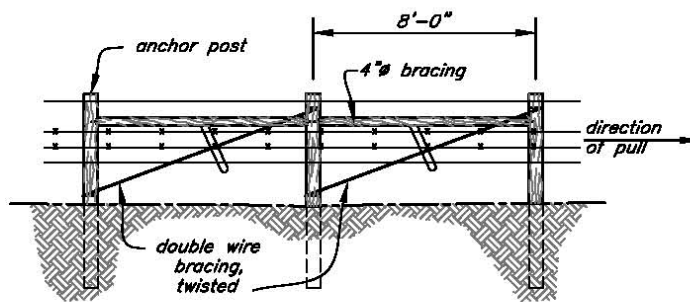

2-SPAN END

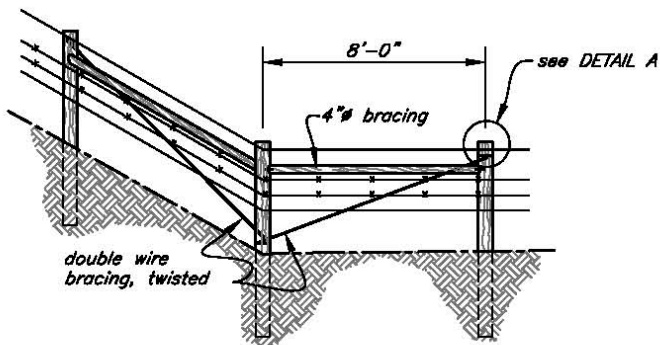

CORNER BRACE

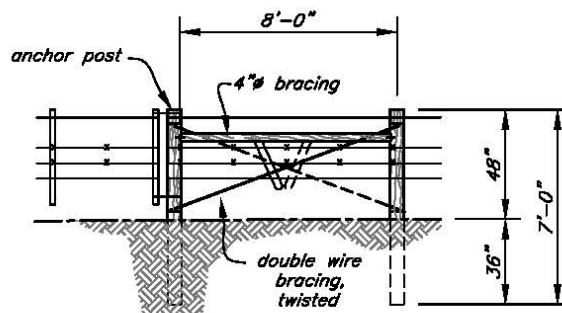

GATE BRACE

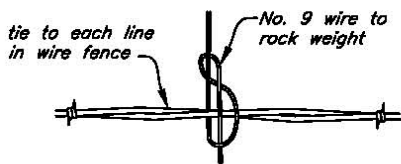

TIEDOWN DETAIL

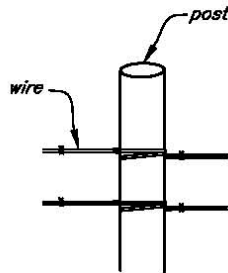

DETAIL A

1. Double wrap all bracing.
2. All brace posts to be 7' long, 3' embedment.
3. Dap braces into posts.
4. Spike braces to posts.