

VERMONT CONSTRUCTION SPECIFICATION

50WW – FENCE, STANDARD WOVEN WIRE

1. Scope

The work shall consist of furnishing and installing standard woven wire fence and related essential components.

2. Materials

Unless otherwise shown on the drawings a standard woven wire fence shall be 47 inches high with low carbon steel woven wire with a single strand of barbed wire 2 inches above the top of the woven wire.

A. Wire

All wire shall be new. The woven wire shall be made of low carbon steel wire with Class 1 galvanizing. The woven wire will be 47 inches high with the top and bottom stands 10.5 gauge or heavier. The intermediate stay wires shall be 12.5 gauge or heavier. The horizontal and vertical stay wires shall be spaced a maximum of 6 inches apart.

The single strand of barbed wire shall be new and consist of 2 twisted strands of 12.5 gauge steel wire with Class 3 galvanizing. Barbs shall be 4 point on 5 inch centers.

B. Fasteners

Staples shall be of 9 gauge class 3 galvanized steel or heavier with a minimum length of 1-3/4 inches for soft wood post or 1 inch for close grain hardwood posts.

Manufacturer's clips or 14 gauge class 3 galvanized wire may be used to fasten wires to steel posts.

C. Posts

Wood. All wooden posts and brace members shall be red cedar, black locust, or pressure treated. Pressure treated posts shall be treated with a minimum of 0.40 lbs/cubic foot of chromated copper arsenate (CCA) Type A, B, or C; or ammoniated copper quat (ACQ) preservative by a method to ensure that complete penetration of the sap wood is obtained. Quality of treated wood shall provide sufficient strength and last the expected life of the fence. All bark shall be removed from red cedar and black locust posts. At least half of the diameter of the red cedar shall be heartwood.

All corner, end, pull and gate assembly posts shall be wooden with a minimum diameter of 6 inches. Assembly post shall be a minimum of 9 feet long for single H-brace assemblies and 8 feet long for double H-brace assemblies.

Line posts shall be at least 4 inches in diameter. Wood line posts shall be a minimum length of 7 feet.

Plastic. Plastic line post shall be at least 4 inches in diameter, able to accept and hold staples, and be durable for the life of the fence. Plastic line post shall be a minimum length of 7 feet.

Steel. Steel line post shall have the standard "T" section, nominal dimensions of 1-3/8" x 1-3/8" x 1/8" with anchor plate. The post shall weigh at least 1.25 pounds per length and painted with weather resistant paint. The post shall be studded to aid in wire attachment. Steel line posts shall be a minimum length of 6 feet.

VERMONT CONSTRUCTION SPECIFICATION

Other. Other materials may be used for line and assembly posts if they are equal or greater in strength and quality of above. Other materials must be approved by the engineer.

3. Construction

A. Post Installation and Spacing.

Live trees used for corner, bracing, and line posts shall have a diameter breast height (DBH) equal to or greater than what is required for normal wooden posts. Some alignment variations shall be allowed, but caution should be taken to minimize offsets and prevent excess fence needs. Wire or insulators will not be fastened directly to trees. A board or boards will be placed on the tree to keep the wire from contacting the bark. Wire shall not be wrapped around the tree. A CCA treated 2"x6" board, fiberglass strip, plastic strip, or an untreated red cedar or white oak board with a minimum size of 1"x4" must be securely fastened to the tree with at least three 40 lbs pole barn nails. The board must be long enough to accommodate the wire. The fence will be fastened to the board with staples

B. Corner, End, Pull and Gate Assemblies.

If the posts are to be set or driven to four feet below the ground line, a single H-brace assembly shall be used.

If the posts are to be set or driven to three feet below the ground line, a double H-brace assembly shall be used.

Bracing is required at all corner, gates, pull, and end assemblies.

All brace members shall be wood and the member centerline shall be 4 to 9 inches below the top of the post. Other brace materials maybe used as approved by the engineer.

The brace member shall be 4 inches in diameter and a minimum of 7 feet in length. A tension member composed of 2 complete loops of 9 gauge smooth wire, 12 gauge double strand wire, or a single loop of 12.5 gauge high tensile strength smooth wire shall be used. One end of the tension member shall be at the height of the horizontal brace member and the other end shall be 4 inches above the ground line on the other posts.

A corner assembly shall be used when the horizontal alignment changes more than 15 degrees and when the vertical alignment changes more than 15 degrees.

Pull assemblies shall be installed at intervals not to exceed 660 feet. The continuity of the wire shall be interrupted at the pull assembly.

C. Line Post.

Wooden and plastic line post shall be set or driven 34 inches below the ground line. If soil depth is less than 28 inches, use standard "T" section posts.

Steel line posts shall be set or drive 23 inches below the ground line.

Post spacing for line posts shall be a maximum of 16 feet.

If post are not driven, the backfill around the post shall be thoroughly compacted.

In areas where soil depth restricts the required embedment depth, additional anchors or deadman applied against the direction of pull, shall be used.

VERMONT CONSTRUCTION SPECIFICATION

D. Fasteners.

The top wire shall be at least 2 inches below the top of wooden posts and 1 inch below the top of steel posts

Staples shall be driven diagonally to the wood's grain and at a slight downward angle, (upward if pull is up) to avoid splitting the post and loosening of the staple. Space should be left between the inside crown of the staple and the post to permit free movement of wire. Barbed staples shall be used for pressure treated posts.

Wires may be attached to steel posts by manufacturer's clips or by two turns of 14 gauge galvanized wire.

Wire shall be spliced by means of "Western Union" splice or by suitable splice sleeves applied with a tool design for the purpose. The "Western Union" splice shall have not less than 8 wraps at each end about the other. All wraps shall be tightly wound and closely spaced.

E. Grounding.

Non-electric wire fences using wood posts shall be grounded at least every 1000 feet. Ground rods should be driven not less than 4 feet into the ground. The rods shall be galvanized steel and a minimum of ½ inch in diameter. All line wires of the fence must be grounded. Alternate grounding materials may be used with the approval of the engineer.

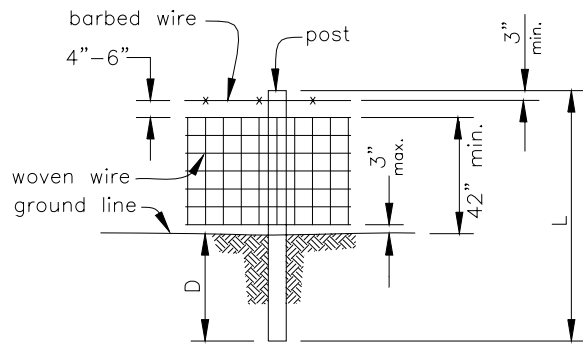
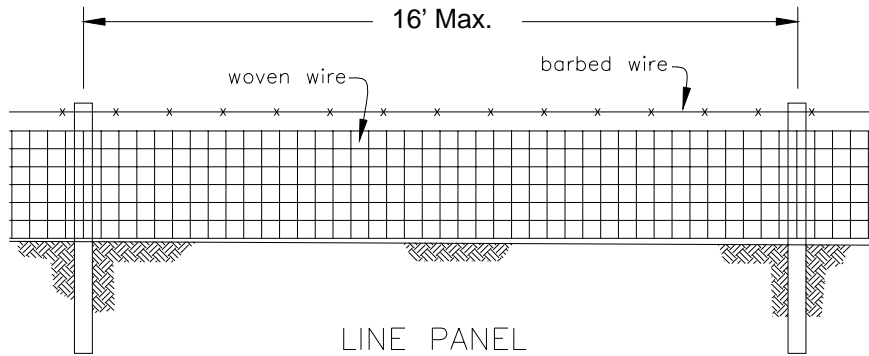

WOVEN WIRE

All wire shall be new. The woven wire shall be made of low carbon steel wire with Class 1 galvanizing. The woven wire will be 47 inches high with the top and bottom strands 10.5 gauge or heavier. Intermediate stays wires shall be 12.5 gauge or heavier. The horizontal and vertical stay wires shall be spaced a maximum of 6 inches apart. Label shall indicated the wire meets ASTM A116 or ASTM A548 standards.

BARBED WIRE

The single strand of barbed wire shall be new and consist of 2 twisted strands of 12.5 gauge steel wire with Class 3 galvanizing. Barbs shall be 4 point on 5 inch centers.

WOVEN WIRE W/ONE BARB DETAIL

LINE Wood: L = 7 ft. min.
D = 2.5 ft. min.
Dia. = 3 in. min.

CORNER OR GATE Wood: L = 7 ft. min.
D = 3 ft. min.
Dia. = 6 in. min.

STAYS Wood: 1-1/2 in. dia. min.
Fiberglass: Any manufactured for this purpose
Wire: 9 1/2 gauge, zinc coated

SPECIES for all wood: White Cedar, Black Locust, or Any Pressure Treated Species

SPECIAL INSTRUCTIONS

Drawing not to scale. Standardized drawing must be adapted to the specific site.

U.S.D.A. NATURAL RESOURCES CONSERVATION SERVICE	JOB CLASS	CLASS	Date
	CAD FILE NO.	FILE	Designed _____
	SHEET	OF	Drawn _____
			Checked _____
		Approved _____	

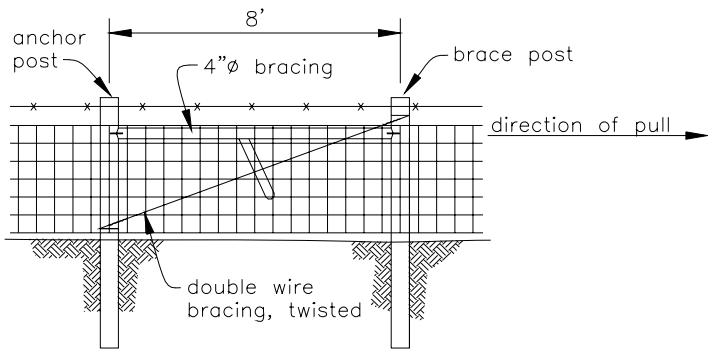

1-SPAN END

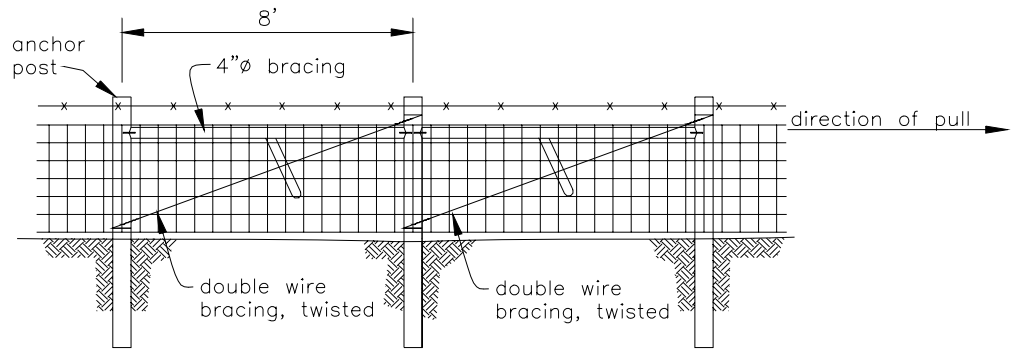

2-SPAN END

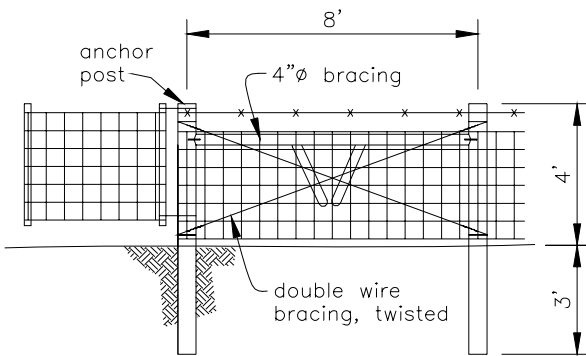

GATE BRACE

1. Double wrap all bracing.
2. All brace posts to be 7' long, 3' embedment.
3. Dap braces into posts.
4. Spike braces to posts.

Drawing not to scale. Standardized drawing must be adapted to the specific site.

JOB CLASS	CLASS	Date
CAD FILE NO.	FILE	Designed _____
SHEET	OF	Drawn _____
		Checked _____
		Approved _____

U.S.D.A. NATURAL RESOURCES CONSERVATION SERVICE

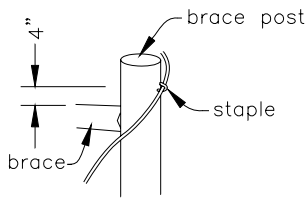

Drive staple about half its length into brace post about 4 inches above brace member on opposite side from brace.

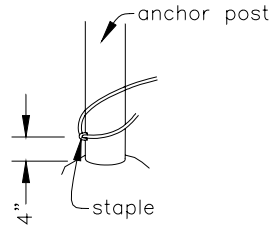

Drive staple in similar manner on anchor post about 4 inches from ground line opposite side of brace.

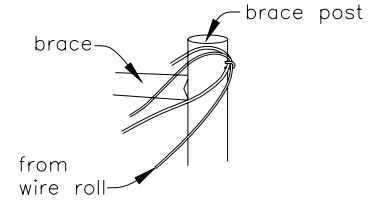

Unroll enough brace wire for two complete loops around anchor and brace post.

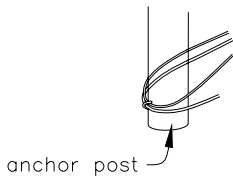

Thread end of brace wire through one staple and then through the other. Repeat to from three wire strands.

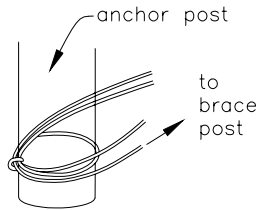

Wrap wire around anchor post and return toward brace post.

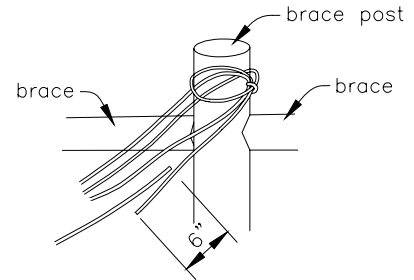

Cut brace wire from roll allowing enough wire to wrap around brace post and extend 6 to 12 inches past other wire end. Make splice.

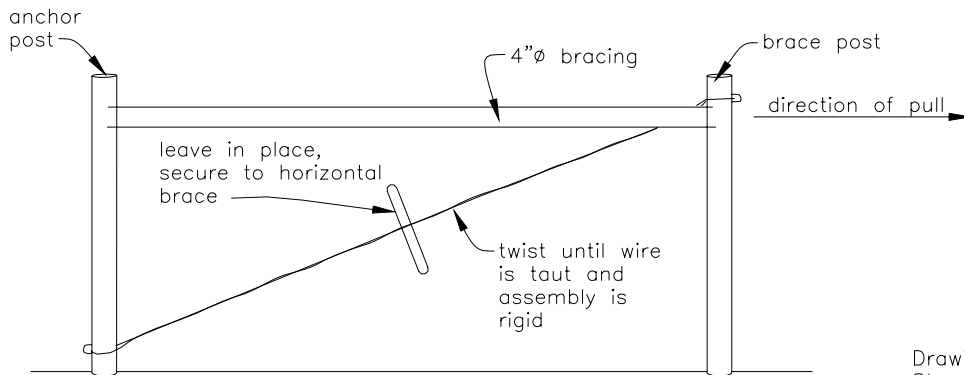
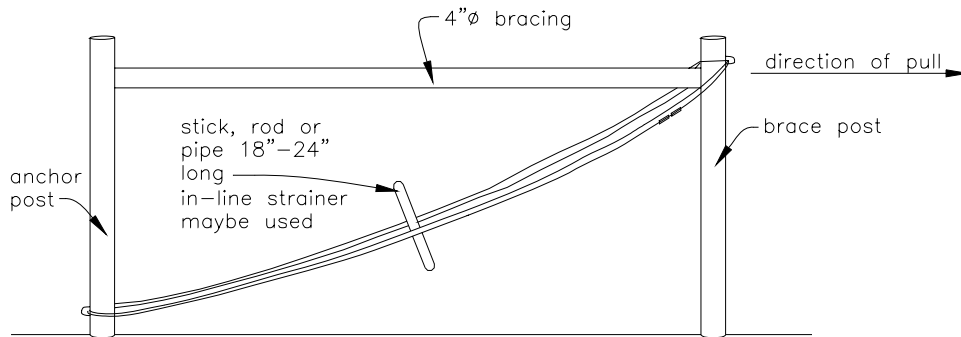

BRACE

Drawing not to scale. Standardized drawing must be adapted to the specific site.

JOB CLASS	CLASS	Date
CAD FILE NO.	FILE	Designed _____
SHEET	OF	Drawn _____
U.S.D.A. NATURAL RESOURCES CONSERVATION SERVICE		Checked _____
		Approved _____

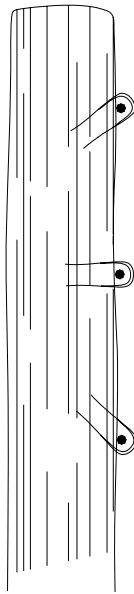

(WIRE PULL IS DOWN)

DRIVE
STAPLES
AT ANGLE

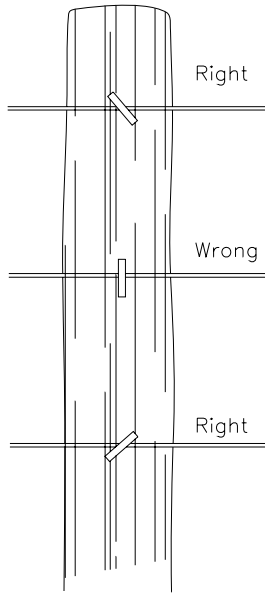

DO NOT DRIVE
STAPLES PARALLEL
TO SIDE OF POST

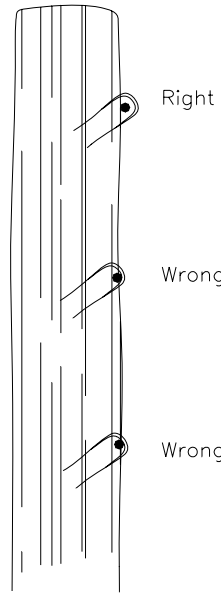

LEAVE
WIRE LOOSE
IN STAPLE

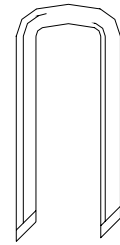

a) No. 9 gauge bright
U-shaped staple,
1-3/4"

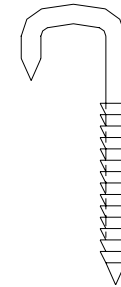

b) No. 9 gauge bright
L-shaped deformed
shank staple, 1-1/2"

ATTACHMENT

STAPLES

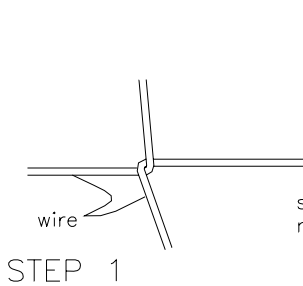
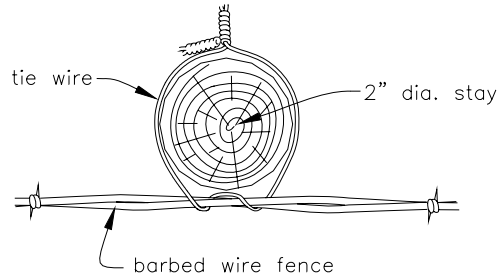
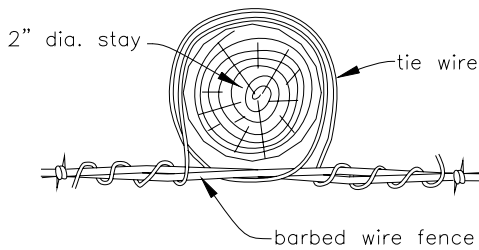

STEP 1

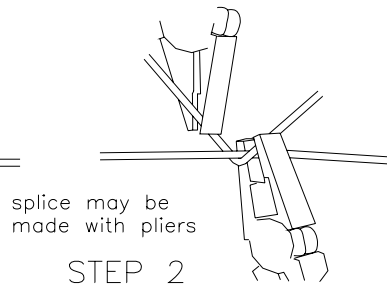

splice may be
made with pliers

STEP 2



completed splice

STEP 3

"WESTERN UNION" SPLICE

U.S.D.A. NATURAL RESOURCES CONSERVATION SERVICE	JOB CLASS	CLASS	Date
	CAD FILE NO.		Designed _____
	FILE		Drawn _____
	SHEET OF		Checked _____
			Approved _____